

Stephen P. McGreevy's BBB-4 (Bare Bones Basic) Natural VLF Radio Receiver Schematic

REVISED RELEASE (June 2002) S. P. McGREEVY. BBB-4 VLF Receiver for broadband 0.1 to 15+ kHz reception of naturally-occurring ELF-VLF radio phenomena. This schematic is being offered as-is. Please see notes at the bottom of this sheet before contacting me about this unit. If all instructions and notes are followed, there should be no problem with it whatsoever. Also, this unit will not receive ULF earthquake signals, nor am I very knowledgeable about such phenomena except for the very basics (I say this to reduce the number of inquiries I receive about such phenomena). If you are interested in ULF reception, try this excellent website: <http://www.vlf.it/index.htm>. Alas, I don't have a better graphical version of this schematic.

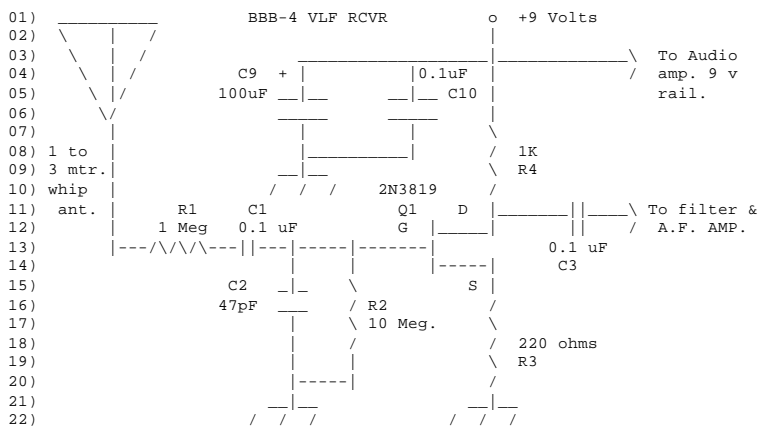

25) AUDIO FILTER L1 (A PI-FILTER USING A COMMON AUDIO XFMR AS INDUCTOR)
 26) * (UUU = coil windings)
 27) (From FET drain coupling cap C3) L1 (1KCT xfmr primary) OR 160-200 milliHenry choke
 28) (Approx. 160 milli-Henries)

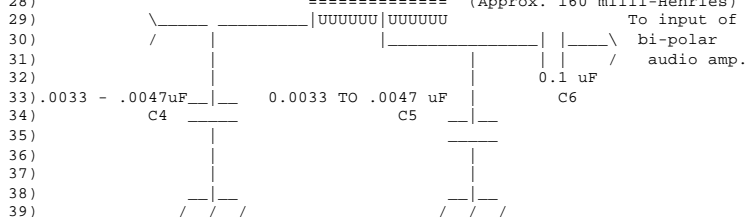

42) *L1 is a 1 KCT pri. to 8 ohm sec. audio xfmr. using one half of primary
 43) winding and the center-tap as a series inductor equalling approx.
 44a) 160 milliHenry. C4 and C5 range from 0.0033 microFarads to 0.0047 microFarads regardless
 44b) of J-FET used. Radio Shack sells the audio-transformer.

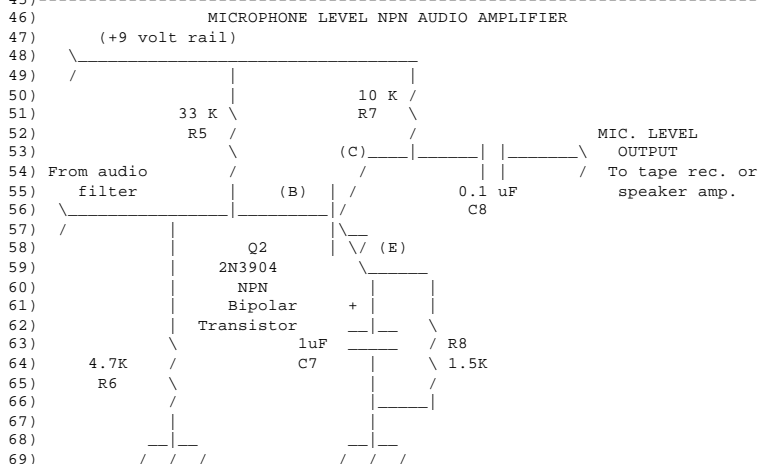

Parts List:
 Caps:
 6 x 0.1 uF

```

1 x 47 pF
2 x .0033 uF or .0047 uF (see notes above or below)
1 x 1 uF electrolytic
1 x 2.2 uF electrolytic (see notes below)
1 x 100 uF electrolytic
---
Resistors:
1 x 1 meg.
1 x 10 meg.
1 x 220 ohm
1 x 33K
1 x 10 K
1 x 4.7 K
1 x 1.5 K
---
2 semiconductors (transistors):
Q1: 2N3819 - a JFET, radio shack cat. # 276-2035
Q2: 2N3904 - a NPN bipolar transistor, radio shack cat # RSU 11328564

Misc:
Audio transformer 8 ohm secondary, 1 K-ohm primary, center tapped, (Radioshack cat. number 273-1380) or subst. 150 milliHenri choke(s)
-----

```

BBB-4 receiver notes and other information:

The "BBB-4" is a broadband 0.2 to 12+ kHz V.L.F. receiver with a passband peak at approximately 1.5 - 2 kHz, and is designed to receive naturally-occurring V.L.F. phenomena (such as "whistlers") that occur as electromagnetic (radio) waves at audio-frequencies. This receiver was designed to be hand-held or tripod mounted, and its output patched to a MICROPHONE-LEVEL input such as a tape-recorder or speaker-amplifier (such as the one available at Radio Shack ("Mini Audio Amplifier/Speaker" cat. # 277-1008). "Radio Shack" in the US and Canada is also known as "Tandy" overseas, such as in the U.K.

It is similar to the ready-made WR-3 I sell in its employment of a whip antenna to successfully and with sensitivity monitor audio frequency VLF Natural Radio. The differences between the BBB-4 and WR-3/3E units are that the BBB-4 does not have a headphone amplifier like the WR-3/3E units nor a switchable audio-filter. This BBB-4 receiver can only be patched either to an outboard speaker/headphone-amplifier or a microphone-level tape recorder input.

Dissatisfied with more complicated and cumbersome multi-turn loop receiver schemes back in 1991, I opted to design a whistler receiver that was simple to build and use by newcomers to this realm of radio. I also desired the BBB-4 to be as sensitive and low-noise as possible using a small whip antenna while being highly immune to broadcast and utility station overload.

The BBB-4 V.L.F. receiver circuit ("BBB-4" standing for a fourth version of my "Bare-Bones-Basic" designs) is remarkably sensitive and works very well with short whip antennas between 1-3 metres in length, since it operates on the same principle as high-impedance "active antennas" designed for other frequency ranges (such as long, medium or shortwaves).

The BBB-4, due to its F.E.T. "front-end" being a high-performance J-FET, has an input impedance of about 10 megohms, which is why the short whip antenna--more correctly called an "electrical-field probe"--works fantastically for being such a tiny fraction of the received-frequencies' wavelengths in size (the ultimate isotropic antenna). R1 and C2 act as a roll-off to frequencies above about 20-30 kHz, efficiently eliminating potential receiver overload/intermod from Lorán-C (100 kHz), strong AM-BCB signals or SWBC signals, and frequencies up into the VHF ranges. R2 sets the gate impedance for the J-FET. R4 and R3 set the optimum bias on the FET for maximum dynamic range and minimum susceptibility to overload and intermod. C3 and C6 slightly helps roll-off low-frequencies such as powerline "hum."

The "pi-filter" consisting of C4, L1 and C5 roll-off frequencies beginning at about 7 kHz, so there are not excessive levels of 10.2 - 13.6 kHz "Omega" signals (AND Russian "ALPHA" in the Eastern hemisphere) or military communication signals in the 18 to 25 kHz range, which can create problems with the recording system (particularly cassette-type recorders) connected to the output of the receiver. Mini-Disc or other recording systems capable of broadband recording past 20 kHz will suffer far less problems from ALPHA and mil. comms., and the pi-filter caps can be further reduced to .002 uF - experiment here if you like. R5 to R8, Q2 and C7 form a fairly low-noise Class-A audio amplifier which boosts the output from Q1 to a level plenty for all microphone-level recorder inputs and even some more "sensitive" line-level inputs. Bypassing R3 (220 ohm) with a 2.2 uF cap will boost FET gain somewhat, esp. the higher frequencies--depending on your location and listening conditions, this may or may not be desirable.

The circuit can be built on perboard such as IC-LSI boards or even wired point-to-point, as layout is not very critical. However, the parts' values ARE critical for optimum passband shape and sensitivity. **It is recommended that this circuit be installed into a metal enclosure for maximum RF shielding.**

A note about R1: experiments in early 2001 have shown that lower receiver J-FET temp. noise results with the substitution of the 1 megohm resistor with (first) a 200K followed by a 150 milliHenri inductor (choke) in series.

L1, the inductor, can either be a 160-200 milliHenry choke or the Radio-Shack 1K to 8 ohm audio transformer available at Radio-Shack (cat. # 273-1380). Use the black and green or black and blue wires (the center-tap and one end of the primary winding).

The audio transformer was used as an inductor, since it is easily available at Radio Shack stores. In fact, ALL the parts are available at Radio Shack. Capacitors C4 and C5 work with L1 to reduce Omega to tolerable levels. Solder the J-FET into the circuit LAST, and take measures to protect the FET from static electricity. The total cost for parts (not including an enclosure) for the BBB-4 are in the neighbourhood of \$15-20 U.S.

E-field-probe receivers of this type need to be operated at locations away from trees, buildings, or other obstacles by about 100 feet/30 metres. This is because received signal levels (due to E-field attenuation) will be poor if the receiver is operated too near (or under) such obstructions.

The greatest nemesis to monitoring and recording naturally occurring VLF phenomena are electric AC powerlines, which emit annoying hum at 50/60 Hertz and also harmonics beyond 1 or 2 kHz. The only cure for this "hum" problem is to locate monitoring sites well away from AC powerlines. Locations at least 1 km/0.6 mi. or so away from a.c. powerlines will begin to be acceptable, though the farther you can get from powerlines, the better. Hilly or mountainous terrain (with open areas free of trees) offer larger areas away from powerlines, though large fields and meadows where the powerlines are shielded by trees, etc. may be surprisingly hum-free. (On the other hand, "low-hum" areas can exist remarkably close to or within towns and cities if most AC lines are below ground.)

Remote locations such as deep into desert and wilderness regions offer the most rewarding locations, both aesthetically and electrically, to listen, and you may be able to get over 10 miles from the nearest powerline. If so, you can make the receiver's antenna several metres in length (keeping it vertical) for maximum sensitivity. Longer vertical antennas or horizontal wires may either overload the receiver, or in the case of long/low wires, will create a mismatch which will actually

reduce output. Experiment here.

NOTE: A 100 milliHenry choke across C5 (the second .0047 cap in the audio filter) will greatly reduce the below 1 kHz frequencies, including pesky power-line hum. This may enable you to listen far closer to AC power-lines including even some backyard locations! Grounding is non-critical. High-impedance FET receivers of this type need only minimal grounding to work well--even just the body of the listener holding the metal enclosure of the receiver will be adequate in most cases. If you wish for really low noise performance in the input stage, replace R1 with a 100 milliHenry choke.

If recording, it is best to stick a 8-10 inch ground rod into the soil to reduce the possibility of feedback with some tape recorders. Also, a small ground-rod (8-10 inches long) will cut noise from body or foot movements (due to capacitive interaction with the ground). If you ground the receiver to objects such as fences, beware that certain grounds may couple AC powerline noise to the receiver, which is why I recommend a simple Earth ground. Better quality tape recorders, with adjustable input level controls, are desirable, as "cheapie" portable recorders with auto-level control will often have annoying variations in record level due to lightning-sferics. And, these cheap recorders also put noise of their own onto the tape.

A shielded 600 ohm patch-cord will suffice between the output of the BBB-4 and microphone input of a tape recorder or speaker amplifier.

The most common naturally occurring V.L.F. emissions to be heard are the myriad "crackling and popping" sounds of lightning-stroke electromagnetic impulses (static/sferics) from lightning storms within a couple thousand-km/mile radius of the listener. Since there are nearly 100 lightning storms in progress anywhere on the Earth at any given time, and that millions of lightning strokes happen daily, there is NEVER a moment when these lightning "sferics" will not be heard. However, the density and strength of lightning sferics can vary day-to-day and hour-to-hour. Mid-winter offers the lowest density of sferics, and summer evenings can be full of a dense barrage of strong sferics masking everything else.

The other most common (and most awesome) sounds are "whistlers"--eerie descending tones caused when the lightning electromagnetic energy gets "ducted" along Earth's magnetic lines-of-force (magnetosphere) to the opposite polar hemisphere, then gets rebounded back to the vicinity of the originating lightning stroke impulse. However, there doesn't have to be lightning within sight or even a few hundred miles of your listening location--lightning from storms up to thousands of km/miles away, particularly if more to the north of your location, can generate large whistlers which are heard continent-wide.

On the other hand, it's quite spectacular to watch safely distant lightning storms generate whistlers in the receiver's output--you hear the huge "crack" of the lightning impulse sferic, then, if the conditions to support whistlers are occurring, a whistler may follow from 1 to 2 seconds after the lightning stroke. Optimum times to listen for natural V.L.F. phenomena, such as whistlers, are between sunset and sunrise, with the midnight to sunrise period generally being the best.

Statistically, the greatest activity to be heard is from 2 a.m. to first-light (dawn) - sferics tend to be fairly low as compared to the sunset period. Dawn Chorus can occur during magnetic storms, and will peak anywhere from an hour before sunrise to 2 hours past sunrise.

Whistlers can occur at anytime, but the period of minimum frequency is midday. Sometimes, activity can also occur just before and after sunset, but sferics will be fiercer. Lightning sferics will be most fierce during summer afternoons and minimum (generally) an hour or so after sunrise until thunderstorm activity picks up later on. Winter can present delightfully low lightning sferics, other activity will be more "in the clear."

Tweeks, the "ringing/pinging" sounds of sferics caused by the Earth-surface/ionosphere "waveguide," will be best from an hour after sunset to 2-3 a.m. local time, gradually tapering off toward sunrise. Their number and intensity of "pinginess" can vary from night to night, some nights they can sound rather "pale," but other nights they can ring in a variety of beautiful mixtures and pitches. Whistlers, which may or may not be heard on some days or even weeks, can range in sound from quite pure notes to very diffuse "breathy" sounds. They can swoop in frequency from very high to low, or abruptly cut-off as they descend in pitch.

If you live north of the about latitude 45 in the US and Canada, or in northern Europe, or extreme southern Australia and New Zealand (closer to the auroral zones), you will likely be able to hear interesting natural radio activity about 50% of the time, especially during magnetically disturbed/storming periods. For those farther south, don't be discouraged if you listen for several hours, or several sessions on different days, without hearing whistlers or other natural radio phenomena. When you DO hear them, it will make up for the "dry" times, as there is nothing like "live" listening! Listeners located north between 40-55 degrees north or south latitude are in the optimum latitudes for monitoring natural V.L.F. phenomena.

If you can see visible Aurora (Northern/Southern Lights) from your location, you are at a great location for natural V.L.F. phenomena monitoring! Latitudes between 20-30 degrees north and south will hear less, but at times, still loud phenomena. I've heard whistlers just fine in Hawaii, presumably those whistlers were louder farther north, but still, they were heard! DO NOT operate this receiver (or any other) when nearby lightning threatens! Take appropriate lightning precautions when lightning is occurring nearby (within 5-10 miles).

Nearby lightning will cause excessively loud sferics in the receiver's output, and whistlers will not be louder just because lightning is close-by. Reserve listening for fair weather periods, most often, the best and loudest natural V.L.F. phenomena will happen during clear weather, since lightning can be quite distant, as mentioned above, and still spawn loud whistlers.

Coordinated monitoring of naturally occurring V.L.F. phenomena among individuals and groups has a strong potential to uncover new and previously unknown characteristics of these phenomena, particularly if those monitoring simultaneously are located hundreds and thousands of miles apart. Research and understanding of V.L.F. phenomena has been hindered by a lack of listeners, which is something a few research groups, both amateur and professional, are attempting to alleviate.

I hope you enjoy this receiver and are interested in monitoring and studying naturally occurring VLF radio phenomena for yourself. It is quite fascinating, especially when one ponders the fact that Earth's natural radio emissions have been "sounding-off" way before we Humans came into existence and started making radio waves of our own!

Happy Listening!

Stephen P. McGreevy

Text and schematic originally released onto the Internet November 1993, updated November 1995, January 1996 with thanks to many rec.radio.shortwave group and Web readers.

Additional Tips:

- 1) A 100-200 milliHenry inductor connected across C5 will act as a high-pass filter, nicely attenuating 60-360 Hz powerline emissions (hum). Experiment here.
- 2) If you want less gain from the Q2 stage (and slightly lower noise), reduce R8 to 4.7K.
- 3) Listen to WWV-shortwave (2.5, 5, 10, 15, 20 MHz) for geo-magnetic indices at 18 min. past each hour (WWVH-Hawaii at :45). A K-index at or above 3 indicates enhanced conditions for natural phenomena, especially chorus.

4) The U.S. NOAA/USAF/Space Environment Center (SEC) runs a fantastic Website with geomagnetic indices and other information available at:<http://sec.noaa.gov>. Lists the past 30+ days' geomagnetic conditions, proton and electron fluences, and so forth. There seems a rough correlation between high electron fluences, low K-indices (especially following a magnetic-storm period) and louder whistlers at middle latitudes-- look for fluences at 1.0E + 07 or higher. This seems to follow best during equinoctial periods (autumn, spring). Periods when the solar flux is rising also seem to be times when whistlers occur more often. Nights of fabulous whistlers can be unpredictable and can't be reliably predicted via "indices," (but it seems lower K indices are better if following a period of higher K indices) so if you have a chance to listen and it's past sunset, do so! Again, high K-indices over 3-4 mean probable chorus (auroral chorus at higher latitudes and dawn chorus at mid. latitudes around dawn and local sunrise. Conditions which hinder HF propagation make Natural Radio come alive!

Stephen P. McGreevy, N6NKS

FINAL NOTE: This E-field VLF receiver schematic and instructions are being offered "as-is." It performs very well as described and in its form shown. Experiment at your own risk and enjoyment. It is made for a 1-3 metre 'whip' (vertical) antennas only. It will not work with ham or SWL antennas, nor loop antennas, nor longwires. It is designed for approx. 300 Hz up to 15 kHz reception--not lower nor higher frequencies. As it is presented herein, it will not receive man-made broadcasts/transmissions such as military VLF stations in the 16-25 kHz spectrum, nor earthquake (ULF) signals below 5 Hz, as some have previously asked me.

It is strictly a 0.4 - 15 kHz receiver for [Natural Radio](#) phenomena listening. I tend to lack time to answer questions about it other than what is presented here. Other than that, have fun with it!!! Commercial-use strictly prohibited without consent of Stephen McGreevy (ask and you may/shall receive...).

NEW!: Dave in north-eastern Holland (Gronigen) sent me this e-mail, saying how well his build of the BBB-4 works. He has a fantastic web site showing photos of his finished receiver and antenna to BNC jack adaptations for use with his own BBB-4. The URL of his web site with this information is:

<http://www.da4e.nl/elfspecial.html>

He also has some .wav recordings of his reception at this site. The text of his e-mail is as follows:

```
Message-ID: <001401bdd387$568a6cc0$b40e86c2@do42>
From: "Dave"
To:
Subject: Whistlers and chorus
Date: Sat, 29 Aug 1998 21:58:05 +0200
```

```
Hi Stephen
I am impressed with the performance of the BBB-4 receiver, I have now built
2 and am avidly busy day and night recording in the very north east of the
Netherlands in the polder areas where there are no cables and trees.
So far I have captured both chorus and whistlers, and am using Gram to
spectrumise the recordings. We had great trouble trying to get the
transformers, so used 2 82 milliH chokes instead. Great stuff. I have been a
radio freak for years, from UHF to LW and now to ELF. I intend to set up a
page(s) on this area with spectrograms and sound bits, I would like to have
the E-mail address of the designer of the Gram program, I could not find his
address anywhere. Also if you have any more details of filtering in
progress.
Thanks so much for the turn on in this region of the atmosphere, as I was
and am busy with the magnetic end of this for some time now.
If you have time, like to hear from you..
best wishes from Holland..
Dave. Website: http://www.da4e.nl/elfspecial.html
```

Rev. 07 January 2002

www.auroralchorus.com

OTHER MCGREEVY LINKS PERTAINING TO VLF RADIO

University of Iowa Plasma Wave Group-hosted URL for fantastic sound files (.WAV) of Natural VLF phenomena:
[McGreevy ground-based VLF recordings at http://www-pw.physics.uiowa.edu/mcgreevy](http://www-pw.physics.uiowa.edu/mcgreevy)