

2 Meter 144 to 148 MHz 2500 Watt 8877 Amplifier Users Guide



AntennaWorks

1301 Crooked mile Ct.
Placerville, Ca 95815
(916) 765-5811

Revision 1.01, 3/24/00

Table of Contents

TABLE OF CONTENTS	2
CHAPTER 1..... SAFETY FIRST!.....	3
CHAPTER 2. INTRODUCTION	4
CHAPTER 3. PARTS LIST.....	5
CHAPTER 4. ASSEMBLY TOOLS AND REQUIREMENTS	6
CHAPTER 5.CAUTION	7
CHAPTER 6. CONNECTING THE POWER SUPPLY TO THE AMPLIFIER	8
CHAPTER 7.CONNECTING THE HIGH VOLTAGE YELLOW WIRE ..	10
CHAPTER 8. CONNECTING THE 240 VOLT PLUG ...	11
CHAPTER 9. RE-CHECK ALL CONNECTIONS ...	12
CHAPTER 10. HOOK UP THE RF CABLES ...	13
CHAPTER 11. COAX RELAY SWITCHING	14
CHAPTER 12. INSTALLING THE TUBE...	15
CHAPTER 13. TUNE AND OPERATION PROCEDURE..	16

Chapter 1. Safety First!

⚡ HIGH VOLTAGE!

⚡ You can be killed so follow safety tips!

- ⚡ Verify there is no voltage present before working with the amplifier.
- ⚡ When in doubt do not touch it.
- ⚡ Install unit safely in a 19-inch rack.
- ⚡ Never open the amp or supply when it is turned on or plugged in.
- ⚡ Wait for capacitor bank to discharge before working on the unit.
- ⚡ Check power cords and high voltage lines often for damage.
- ⚡ Enjoy your amplifier and always be cautious.

Chapter 2. Introduction

Welcome to world class VHF operation using the Antenna Works 2 meter 144 to 148 MHz 2500 watt 8877 amplifier. This amplifier has been adapted from the original W6PO 8877 Eimac Amateur Service Newsletter - W6SAI 1971. Many years of design improvements has brought this amplifier to what it is today. This is a high efficiency and high power amplifier for the VHF enthusiast.

We here at AntennaWorks wish you good contacts using the amplifier for your EME or terrestrial VHF contacts. Using the Antenna Works VHF amplifier will enable you to achieve extreme distant contacts. We know you will be thrilled by its performance.



Chapter 3. Parts List

AntennaWorks 2 Meter 144 to 148 MHz 2500 Watt 8877 Amplifier:

- 2 meter 144 to 148 MHz 2500 watt 8877 amplifier
- AntennaWorks 2 Meter Amplifier power supply.
- Conduit for power supply connection
- High voltage connector

OPTIONS:

Relays:

- RF Relays

Meters:

- Surelite
- Simpson

Tube:

- Eimac 3cx1500A7 S/N _____ Date _____
Code _____

Other:

- _____
- _____
- _____
- _____

Signed _____ Date _____

QC _____ Date _____

Chapter 4. Assembly Tools and Requirements

The following is needed to assemble the Antenna Works amplifier.

Phillips #2 Screwdriver

Small flat Head Screwdriver

Wire Cutter

Wire Stripper

Solder

Solder Iron

Chapter 5. Caution

If you are uncomfortable or unknowledgeable about high voltage safety and assembly, seek qualified personnel to assemble the amplifier for you. Do not attempt assembly without proper knowledge.

Chapter 6. Connecting the Power Supply to the Amplifier

If you are going to use the gray conduit to go from the supply to the amp you must put all wires including the Yellow high voltage wire through the conduit before you start this section. Fasten the gray conduit from the power supply to the fan and feed all wires including the Yellow high voltage wire out the fan.

Hooking up amp to supply is easy as 1 to 8. The terminal strip with 8 positions is located on the left rear of the RF decks left side looking at it from the front. Number the positions 1 through 8 from top to bottom. Refer to figure 1.

Please start with position no.1 at the top of the terminal strip. The power supply has a purple wire. This is chassis ground to chassis ground. Strip off 3/16" of insulation from the end of the wire. Hook the purple wire to position no. 1 Use the flat head screwdriver to tighten the terminal screw holding the wire.

Look at position nos. 2 and. 3. These are your PTT. 12 VDC are present here. Short these together to put the amp in the TX mode. To add user control of the PPT remove the jumper from position no. 2 and 3 and add your own control wires.

Look at position nos. 4 and 5. These are a pair connected directly to the front panel of the amp. The High Voltage Turn on Switch is the only place the brown and orange wires go. Strip off 3/16" of insulation from the end of each wire. Connect the brown wire to position 4 and the orange wire to position 5. This allows the high voltage to get turned on after a 90-second filament and fan warm-up time.

Look at position 6. CAUTION: 6 is red, it is hot 120 VAC, and goes to the fan and filament switch. It is live all the time and can shock you. Strip off 3/16" of insulation from the end of the wire. Connect the red wire to position 6.

Look at position 7. 7 is green and is the 120-volt return as well as chassis ground. Strip off 3/16" of insulation from the end of the wire. Connect the green wire to position no. 7.

Look at position 8. 8 is black and is the return. There will only be a low DC voltage here due to the bias configuration, but a good solid connection is most important here. Strip off 3/16" of insulation from the end of the wire. Connect the black wire to position no. 8.

Check your connections:

1 purple = ground

2 and 3 together = PTT

4 brown and 5 orange = High Voltage turn on (120 VAC here).

6 red and 7 green = 120 VAC to run fan and filament.

8 black = b-return.

Re-torque each position of the terminal strip.

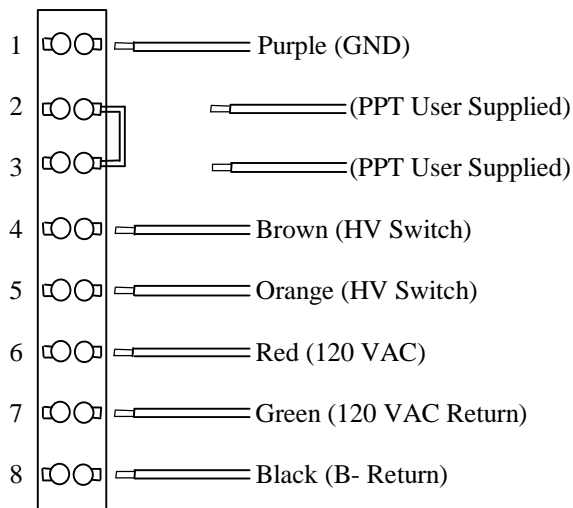

Figure 1. 8 position terminal strip

Chapter 7. Connecting the High Voltage Yellow Wire

If using the gray conduit, you can fasten the gray conduit from the power supply to the fan and feed the Yellow high voltage wire through the fan to its high voltage connector using the high voltage connector supplied.

To connect the high voltage yellow wire to the amplifier, strip off 1.25 inches of insulation from the end of the yellow wire from the supply.

Solder on the red high voltage connector. This is the 4,000 VDC that supplies the RF deck. Connect the red high voltage connector to the RF deck.

Do not over tighten.

If you see any bare wire during this process, start over.

Think safe and hide the wires.

Chapter 8. Connecting the 240 Volt Plug

Choose a power plug good for at least 25 amps. Your amp is regulated with a 20-amp push breaker, but a bit of overkill here on your part won't hurt, and it will also help your high voltage regulation if you are connected to a high current line.

Green is your ground. Black, and white are your two hot lines. Follow the instructions that come with your plug for proper installation.

Chapter 9. Re-Check all Connections

Check all wires; make sure all tools are clear.

Verify the screws are tight, the wires are safely connected and that the yellow wire is away from any possible items that could nick, scratch, pinch, cut, pull, or put strain on the cable that could damage the Yellow high voltage wire in any way.

Use the supplied gray conduit and connect the fan to the supply with it. This is the recommended method.

Think safe! If you are not sure at any point, stop and call us at (916) 765-5811 for advice. We will answer calls promptly.

Chapter 10. Hook up the RF Cables

Hook up your radio to a SWR/wattmeter.

Hook up the SWR/wattmeter to the tuned input box on the back of the amplifier.

Hook up load or antenna to a high power meter, and hook up the meter to the amplifier output.

Turn on the fan/filament switch. Wait 90 seconds warm up time and apply 10 watts or so and read output power. Peak the front tune knob for most power. Watch plate, grid, and meters. The grid should read almost nothing, or slightly negative.

The grid should never rise above 80 milliamps of current. This condition only occurs with very high power input levels of 80 watts or more.

If you have gain now, make sure the SWR between the radio and amplifier is 1.5 or less. Adjust the one screw on the tuned input box can lower SWR if it is over 1.5 to 1.

Chapter 11. Coax Relay Switching

Most people find it nice to use 2 coax runs if an upper pre-amp will be used.

If you need 28 volts for relays there is a diode block on the left side of the amp wired for you if needed.

There is a spare set of contacts on the 9-pin relay socket for switching which happens during the PTT mode.

There is an AUX switch on the front panel if you need any external on-off control.

Give us a call at (916) 765-5811 if you need help with relays, or a good way to configure your system for EME or other modes.

Chapter 12. Installing the Tube

Remove lid from RF deck.

Place chimney (Teflon) over tube socket.

Take the tube with the anode assembly attached and install it in the tube socket.

Put the square inductor clamps over the silver tubing on each side. Slide them flush with the top of the silver tubes.

Tighten the clamps with a flat screwdriver from the rear access holes.

Solder the high voltage RF choke onto the anode clamp.

Re-install RF deck lid.

Check for shorts or damage during this process.

Call (916) 765-5811 if you have any questions.

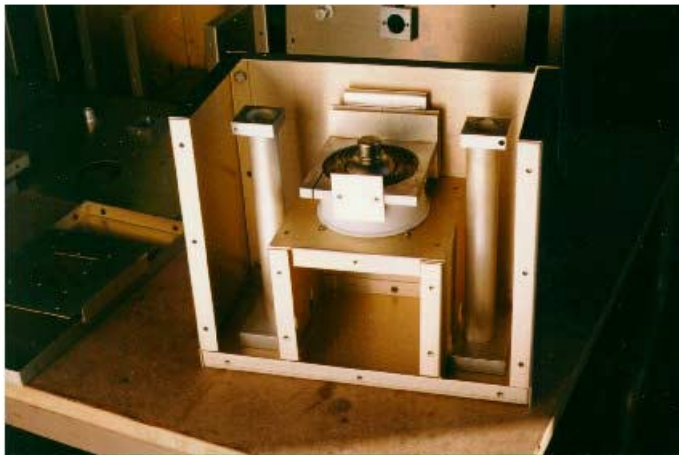

Chapter 13. Tune and Operation Procedure

Keep it legal.

Your drive level is up to you. The amplifier is able to exceed output levels regulated by the FCC. We build a product that is able to exceed legal limit so it will work well at legal duty cycles. If you exceed these levels, premature tube wear will occur, so keep it within a drive of 75 watts or less so it will last a long, long time.

Remember the amplifier is set up at the shop here, so only tuning of the front tune knob should be necessary. If you adjust the plate loading in the back, loosen the plate loading screw, make a small adjustment and then re-tune the front for max power out, while watching the grid current. A closer spacing will lower the grid current. You want high power and reasonable grid current. Never exceed 80 milliamp grid current.